

KP

- 超长寿命: 10000 小时 Ultra long life:10000 hours
- 适用于开关电源, 变频器 Best for switching power supplies, Inverter.
- ROHS 指令已对应完毕。Adapted to the ROHS directive.

主要技术性能 Specifications

项目 Item	特性 Performance Characteristics							
使用温度范围 Operating temperature range	-25°C ~ +85°C							
额定电压范围 Rated voltage range	200 ~ 450 V							
标称容量允许偏差 Capacitance tolerance	±20% (120Hz, +20°C)							
漏电流 Leakage current	$I \leq 3\sqrt{CV}$ (μA) 5分钟 (at 20°C, after 5minutes)							
损耗角正切值 (tg δ) Dissipation factor (+20°C, 120Hz)	<table border="1"> <tr> <td>U_R (V)</td> <td>200~250</td> <td>400~450</td> </tr> <tr> <td>tg δ</td> <td>0.15</td> <td>0.20</td> </tr> </table>	U _R (V)	200~250	400~450	tg δ	0.15	0.20	
U _R (V)	200~250	400~450						
tg δ	0.15	0.20						
温度特性 Temperature characteristics (Impedance ratio at 120Hz)	<table border="1"> <tr> <td>U_R (V)</td> <td>200~250</td> <td>400~450</td> </tr> <tr> <td>Z-25°C/+20°C</td> <td>3</td> <td>8</td> </tr> </table>	U _R (V)	200~250	400~450	Z-25°C/+20°C	3	8	
U _R (V)	200~250	400~450						
Z-25°C/+20°C	3	8						
耐久性 Load life	+85°C施加带额定纹波电流的额定电压 10000 小时, 恢复 16 小时后: After applying rated voltage with specified ripple current for 1000 hours at +85°C and then resumed 16 hours: 电容量变化率 Capacitance change : ±30%初始测量值以内 Initial measured value 漏电流 Leakage current : ≤初始规定值 Initial specified value 损耗角正切值 Dissipation factor : ≤3 倍初始规定值 3 times Initial specified value							
高温贮存 Shelf life	+85°C, 1000 小时贮存后, 加额定工作电压处理 30 分钟, 恢复 16 小时后: After storage for 1000 hours at +85°C, U _R to be applied for 30 minutes and then resumed 16 hours 电容量变化率 Capacitance change : ±15%初始测量值以内 Initial measured value 漏电流 Leakage current : ≤初始规定值 Initial specified value 损耗角正切值 Dissipation factor : ≤1.5 倍初始规定值 1.5times Initial specified value							

外形图 Case table

单位Unit: mm

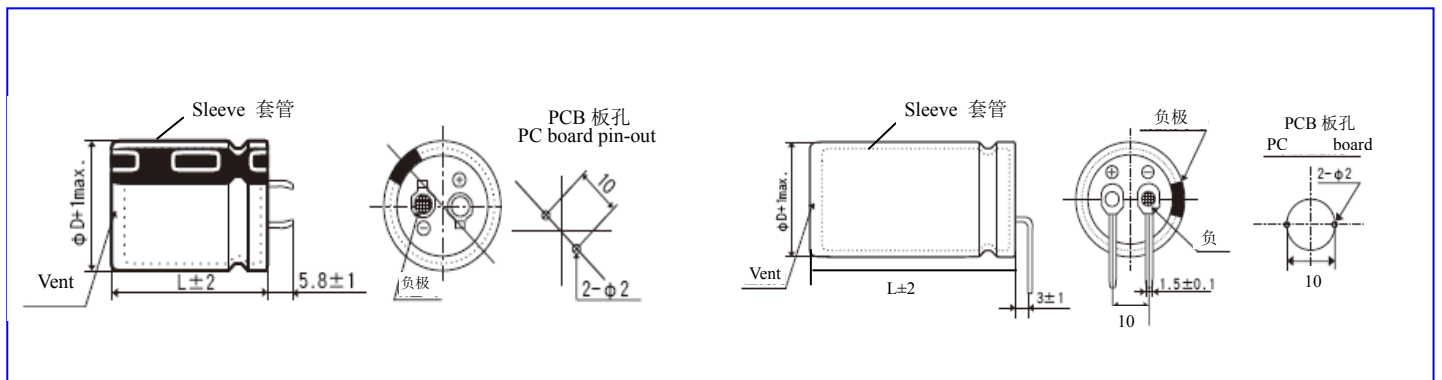

频率修正系数 Frequency coefficient

Freq.(Hz)	50	120	1K	10K	≥50K
U(V)	50	120	1K	10K	≥50K
200~450	0.80	1.00	1.30	1.41	1.43

尺寸 DIMENSIONS

WV Size CAP(μF)		200V (2D)								250V(2E)							
		Φ 22		Φ 25		Φ 30		Φ 35		Φ 22		Φ 25		Φ 30		Φ 35	
		Size	Ripple	Size	Ripple	Size	Ripple	Size	Ripple	Size	Ripple	Size	Ripple	Size	Ripple	Size	Ripple
220	221									22×30	1.18						
270	271	22×25	1.30							22×35	1.43						
330	331	22×25	1.44							22×40	1.58	25×35	1.53				
390	391	22×30	1.65	25×25	1.63					22×45	1.79	25×40	1.79				
470	471	22×35	1.88	25×30	1.86					22×50	2.05	25×45	2.05	30×35	1.94		
560	561	22×40	2.08	25×30	2.05	30×25	2.05					25×50	2.24	30×40	2.24		
680	681	22×45	2.36	25×35	2.36	30×30	2.36							30×45	2.58		
820	821	22×50	2.68	25×40	2.68	30×30	2.62							30×50	2.84	35×40	2.82
1000	102			25×45	3.12	30×35	3.00	35×30	2.96							35×45	3.31
1200	122			25×50	3.44	30×40	3.44	35×35	3.40							35×50	3.66
1500	152					30×50	3.93	35×40	3.87								
1800	182							35×45	4.37								
2200	222							35×50	5.00								

WV Size CAP(μF)		400V(2G)								450V(2W)							
		Φ 22		Φ 25		Φ 30		Φ 35		Φ 22		Φ 25		Φ 30		Φ 35	
		Size	Ripple	Size	Ripple	Size	Ripple	Size	Ripple	Size	Ripple	Size	Ripple	Size	Ripple	Size	Ripple
68	680									22×25	0.68						
82	820	22×25	0.80							22×30	0.82						
100	101	22×30	0.94							22×35	0.90	25×25	0.92				
120	121	22×30	1.04	25×25	1.08					22×35	1.02	25×30	1.04	30×25	1.07		
150	151	22×35	1.18	25×30	1.21					22×40	1.12	25×35	1.19	30×30	1.23		
180	181	22×40	1.34	25×35	1.37	30×25	1.45			22×50	1.26	25×40	1.33	30×30	1.38		
220	221	22×45	1.50	25×35	1.56	30×30	1.58					25×45	1.51	30×35	1.56	35×30	1.58
270	271			25×40	1.70	30×35	1.73					25×50	1.65	30×40	1.80	35×35	1.81
330	331			25×50	1.90	30×40	1.95	35×30	1.95					30×45	2.02	35×35	2.05
390	391					30×40	2.15	35×35	2.17					30×50	2.24	35×40	2.27
470	471					30×50	2.39	35×40	2.42							35×45	2.55
560	561							35×45	2.71								
680	681							35×50	2.95								

Size φ D×L(mm)

Maximum Allowable Ripple Current (A rms)at 85°C 120Hz