

AP

- 耐高纹波,小尺寸,85°C 2000 小时
High ripple current ,Smaller size ,Load life of 2000 hours at 85°C.
- 适用于开关电源,变频器 Best for switching power supplies, Inverter.
- ROHS 指令已对应完毕。
Adapted to the ROHS directive

主要技术性能 Specifications

项目 Item	特性 Performance Characteristics																																								
使用温度范围 Operating temperature range	-40°C ~ +85°C	-25°C ~ +85°C																																							
额定电压范围 Rated voltage range	10 ~ 100 V	160 ~ 450 V																																							
标称电容量允许偏差 Capacitance tolerance	±20% (120Hz, +20°C)																																								
漏电流 Leakage current	I ≤ 0.01CV(μA)或1.5mA 取较小值 (Whichever is smaller) 5分钟 (at 20°C, after 5 minutes)																																								
损耗角正切值 (tg δ) Dissipation factor (+20°C, 120Hz)	<table border="1"> <thead> <tr> <th>Cap(μF) \ U_R(V)</th> <th>10~16</th> <th>25</th> <th>35~50</th> <th>63</th> <th>80~100</th> </tr> </thead> <tbody> <tr> <td>≤2700</td> <td></td> <td></td> <td>0.20</td> <td>0.15</td> <td>0.15</td> </tr> <tr> <td>3300~4700</td> <td></td> <td>0.35</td> <td>0.25</td> <td>0.20</td> <td>0.15</td> </tr> <tr> <td>5600~6800</td> <td>0.40</td> <td>0.35</td> <td>0.30</td> <td>0.20</td> <td>0.20</td> </tr> <tr> <td>≥8200</td> <td>0.40</td> <td>0.35</td> <td>0.35</td> <td>0.25</td> <td></td> </tr> </tbody> </table>	Cap(μF) \ U _R (V)	10~16	25	35~50	63	80~100	≤2700			0.20	0.15	0.15	3300~4700		0.35	0.25	0.20	0.15	5600~6800	0.40	0.35	0.30	0.20	0.20	≥8200	0.40	0.35	0.35	0.25		<table border="1"> <thead> <tr> <th>U_R(V) \ Φ D(mm)</th> <th>160~250</th> <th>350~450</th> </tr> </thead> <tbody> <tr> <td>30</td> <td>0.15</td> <td>0.20</td> </tr> <tr> <td>35~40</td> <td>0.18</td> <td>0.20</td> </tr> </tbody> </table>	U _R (V) \ Φ D(mm)	160~250	350~450	30	0.15	0.20	35~40	0.18	0.20
Cap(μF) \ U _R (V)	10~16	25	35~50	63	80~100																																				
≤2700			0.20	0.15	0.15																																				
3300~4700		0.35	0.25	0.20	0.15																																				
5600~6800	0.40	0.35	0.30	0.20	0.20																																				
≥8200	0.40	0.35	0.35	0.25																																					
U _R (V) \ Φ D(mm)	160~250	350~450																																							
30	0.15	0.20																																							
35~40	0.18	0.20																																							
温度特性 Temperature characteristics (Impedance ratio at 120Hz)	<table border="1"> <thead> <tr> <th>U_R(V)</th> <th>10</th> <th>16~35</th> <th>50~100</th> <th>160~250</th> <th>350~400</th> <th>450</th> </tr> </thead> <tbody> <tr> <td>Z-25°C/+20°C</td> <td>5</td> <td>4</td> <td>3</td> <td>4</td> <td>8</td> <td>8</td> </tr> <tr> <td>Z-40°C/+20°C</td> <td>18</td> <td>15</td> <td>10</td> <td></td> <td></td> <td></td> </tr> </tbody> </table>						U _R (V)	10	16~35	50~100	160~250	350~400	450	Z-25°C/+20°C	5	4	3	4	8	8	Z-40°C/+20°C	18	15	10																	
U _R (V)	10	16~35	50~100	160~250	350~400	450																																			
Z-25°C/+20°C	5	4	3	4	8	8																																			
Z-40°C/+20°C	18	15	10																																						
耐久性 Load life	+85°C施加带额定纹波电流的额定电压 2000 小时, 恢复 16 小时后: After applying rated voltage with specified ripple current for 2000 hours at +85°C and then resumed 16 hours: 电容量变化率 Capacitance change : ±20%初始测量值以内 Initial measured value 漏电流 Leakage current : ≤初始规定值 Initial specified value 损耗角正切值 Dissipation factor : ≤2 倍初始规定值 2times Initial specified value																																								
高温贮存 Shelf life	+85°C,1000 小时贮存后,加额定工作电压处理 30 分钟,恢复 16 小时后: After storage for 1000 hours at +85°C, U _R to be applied for 30 minutes and then resumed 16 hours 电容量变化率 Capacitance change : ±15%初始测量值以内 Initial measured value 漏电流 Leakage current : ≤初始规定值 Initial specified value 损耗角正切值 Dissipation factor : ≤1.5 倍初始规定值 1.5times Initial specified value																																								

外形图 Case table

单位Unit: mm

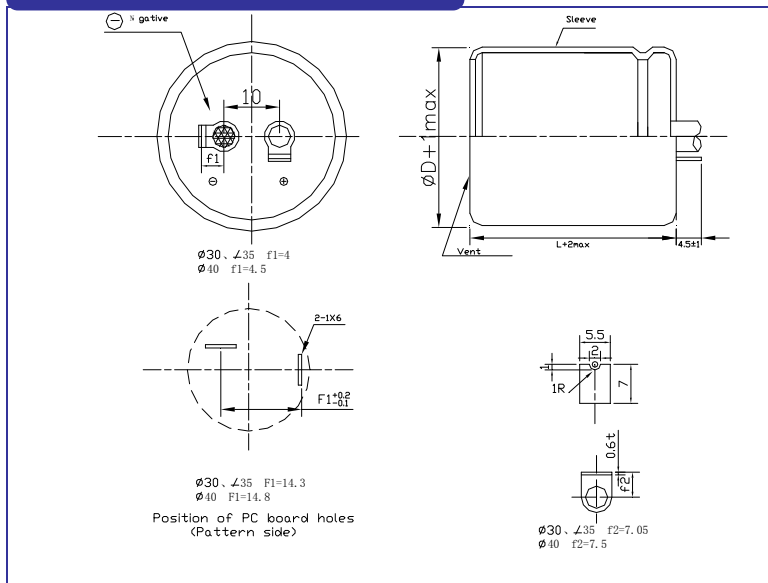

频率的修正系数 Frequency coefficient

频率(Hz) \ U(V)	50	100 (120)	1K	10K	100K
≤100	0.95	1.00	1.10	1.15	1.15
160~450	0.8	1.00	1.30	1.41	1.43

WV ΦD CAP(μF)		200 (2D)				250 (2E)				350(2V)			
		30		35		30		35		30		35	
		Size	Ripple	Size	Ripple	Size	Ripple	Size	Ripple	Size	Ripple	Size	Ripple
180	181									30×25	1.10		
220	221									30×30	1.20	35×25	1.30
270	271									30×35	1.40	35×30	1.40
330	331					30×25	1.50			30×40	1.60	35×30	1.60
390	391					30×30	1.70			30×40	1.70	35×35	1.80
470	471	30×25	1.90			30×30	1.80	35×25	2.10	30×45	2.00	35×40	2.00
560	561	30×30	2.10	35×25	2.00	30×35	2.00	35×30	2.30			35×45	2.30
680	681	30×35	2.40	35×30	2.30	30×40	2.30	35×30	2.60			35×50	2.60
820	821	30×40	2.70	35×30	2.50	30×45	2.60	35×35	2.60				
1000	102	30×45	3.10	35×35	2.80			35×40	3.00				
1200	122	30×50	3.40	35×40	3.20			35×45	3.40				
1500	152			35×50	3.80								

WV ΦD CAP(μF)		400 (2G)				420 (2M)				450(2W)			
		30		35		30		35		30		35	
		Size	Ripple	Size	Ripple	Size	Ripple	Size	Ripple	Size	Ripple	Size	Ripple
150	151	30×25	1.20			30×25	1.10			30×30	1.10		
180	181	30×30	1.40	35×25	1.40	30×30	1.30	35×25	1.30	30×35	1.20	35×25	1.20
220	221	30×35	1.30	35×30	1.40	30×35	1.30	35×30	1.30	30×40	1.30	35×30	1.30
270	271	30×40	1.50	35×30	1.50	30×40	1.40	35×30	1.40	30×45	1.40	35×35	1.50
330	331	30×45	1.60	35×35	1.70	30×45	1.50	35×35	1.60			35×40	1.70
390	391	30×50	1.80	35×40	1.80	30×50	1.70	35×40	1.70			35×45	1.90
470	471			35×45	2.10			35×45	1.90			35×50	2.20
560	561			35×50	2.30			35×50	2.30			35×60	2.50
680	681			35×60	2.70			35×60	2.60			35×60	2.80

Size ΦD×L(mm)

Maximum Allowable Ripple Current (A rms) at 85°C 120Hz

